



Basto

An integrated intelligent garden lighting system offering multiple functions, customizable to meet the specific needs of customers.

Key features

- The top cover is made from die-cast aluminum and the column pole is extruded aluminum with customizable height, to meet client requirements, featuring a PC transparent diffuser
- Offers two types of light distribution: asymmetric and symmetric optics, with a top SMD light source providing a visually comfortable lighting effect
- Equipped with high-quality LED chips and a driver supporting 0-10V/DALI/programmed options, including surge protection up to 20KV
- Incorporates an LED module and integrated electrical components that are easy to install and replace
- The surface is coated with anti-ultraviolet pure polyester powder paint, providing corrosion resistance for over 1000 hours
- Meets EN 62471:2008 standards, guaranteeing no photo-biological risks such as infrared, blue light, or UV radiation
- Features smart street lighting control technology, compatible with remote management systems

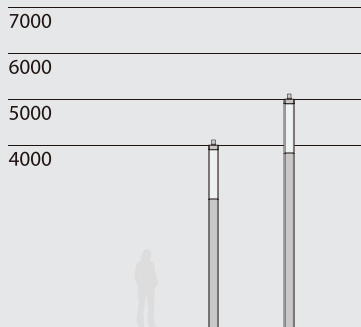

Accessories



Anchor Bolts





Dimensions

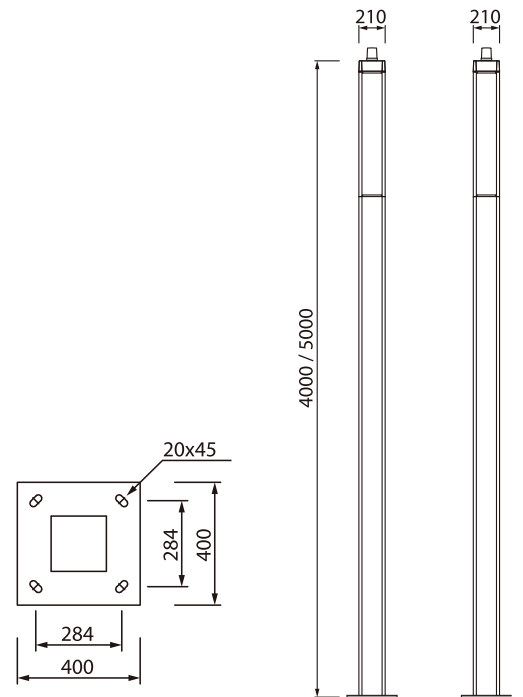

Photometry

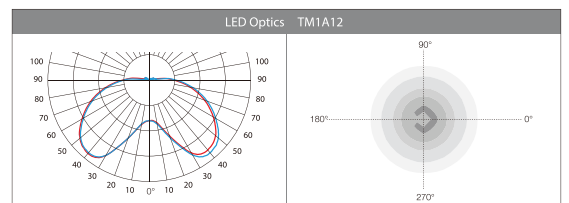
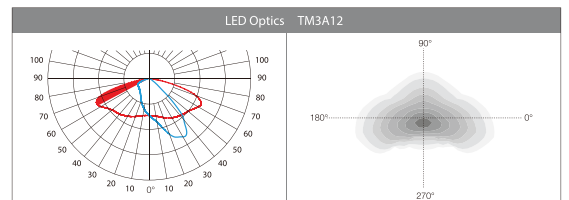

Technical Data

Code	Power	LED Qty	Optics	Weight
Basto-LED-60-400	60W	24	TM1A24/ TM3A24	57
Basto-LED-60-500	60W	24	TM1A24/ TM3A24	66