

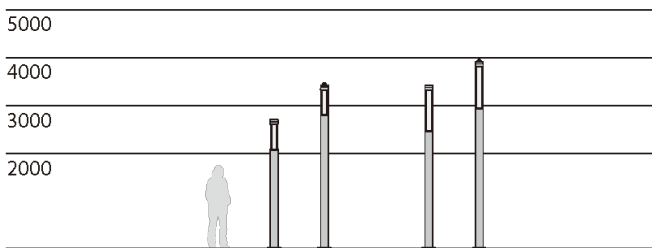

Stango

Key features

- The top cover is made from die-cast aluminum, and the column pole is extruded aluminum, with height customizable to client specifications. It also includes a PC transparent diffuser
- The light distribution comes in two forms: a top SMD light source with a diffusion cover and an anti-glare louvre
- Equipped with high-quality LED chips and driver supporting 0-10V/DALI/programmed options, including surge protection up to 20KV
- The integrated LED module and electrical components are designed for easy installation and replacement
- The surface is coated with anti-ultraviolet pure polyester powder paint, providing corrosion resistance for over 1000 hours
- Compliant with EN 62471:2008 standards, ensuring no photo-biological risks such as infrared, blue light, or UV radiation
- The street lighting control features smart technology compatible with remote management systems
- All external screws are made from 304 stainless steel for enhanced durability



Accessories



Anchor Bolts





Dimensions

STANGO

STANGO L

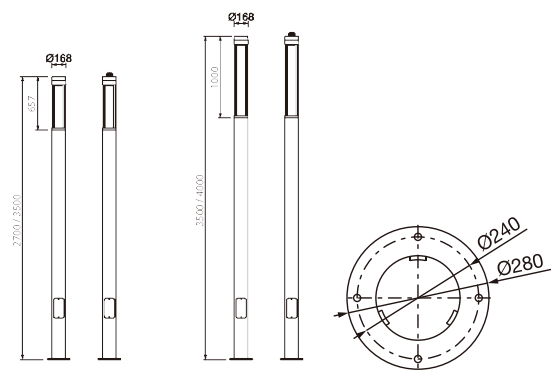

Photometry

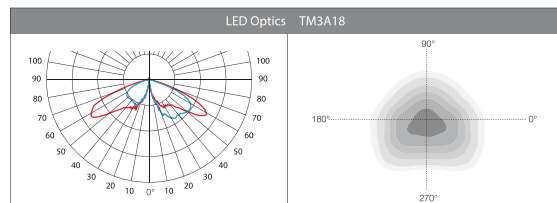
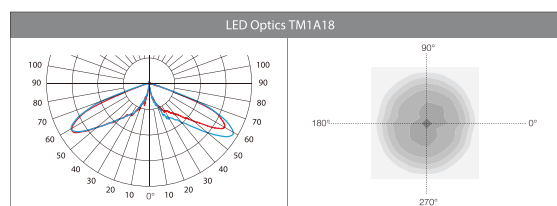

Technical Data

Code	Power	LED Qty	Optics	Weight
Stango-LED-50-18-270	50W	18	TM1A18/ TM3A18	27
Stango-LED-50-18-350	50W	18	TM1A18/ TM3A18	19
Stango-L-LED-50-18-350	50W	18	TM1A18/ TM3A18	20
Stango-L-LED-50-18-400	50W	18	TM1A18/ TM3A18	20